



TideONCORE 7" & CORE 9" Chart Plotter Manual

SAFETY INSTRUCTIONS

Safety Instructions for the Operator

- *WARNING: Do not open the equipment. Only qualified personnel are permitted to work inside the equipment.*
- *Do not disassemble or modify the equipment. Fire, electric shock, or serious personal injury may occur.*
- *Immediately turn off the power at the panel if the equipment emits smoke or fire. Continued use may cause fire or electric shock. Contact a TIDEON dealer for service.*
- *Use the correct fuse. An incorrect fuse may damage the equipment or cause fire.*

- *Ensure that the power supply is compatible with the equipment. An incorrect power supply may cause the equipment to overheat.*
- *Operating temperature: -15°C to 55°C for the Display Unit. Use outside this range may damage the equipment.*

Safety Instructions for the Installer

- *WARNING: Do not open the equipment unless you are fully familiar with electrical circuits and the service manual. Improper handling may result in electric shock.*
- *Turn off power at the panel before installation. Fire or electric shock may occur if the power is turned on.*
- *Ensure that the power supply matches the equipment's voltage rating. Incorrect connection may cause fire or injury.*
- *Use the correct fuse. An incorrect fuse may damage the equipment or cause fire.*

FOREWORD

TIDEON chart plotters are sealed and rated IPX6 waterproof.

Definition of IPX6:

IPX6 means the product is waterproof against powerful water jets, but not necessarily against immersion in water.

The plotters can quickly determine position and are resistant to harsh environments. The software is powerful, with advanced processors enabling fast display, and the operation is professionally and intuitively designed for ease of use. The built-in charts provide intuitive and precise navigation. Suitable for navigation and positioning on various vessels at sea and on rivers, as well as for hydrographic data collection, among other uses.

But REMEMBER the built-in chart is for guidance only and can never replace an actual paper chart.

Features:

- Easy to operate
- Ultra-high brightness LCD, visible in bright sunlight
- Compatible with multiple chart systems: C-MAP, Navionics, K-Chart2.0, and K-Chart3.0
- High-resolution LCD
- Optional NMEA0183 output Baud Rate and sentences
- Free use of TIDEON's detailed worldwide K-Chart system
- IPX6 waterproof
- Supports NMEA2000 (N2K)

PERFORMANCE AND SPECIFICATIONS

Chart Plotter

- Waypoints: 12,000 user waypoints with name and symbol.
- System waypoints: 3 system waypoints: MOB, Start, Cursor.
- Proximity waypoints: 10 proximity waypoints.
- Routes: Max. 30 routes, up to 170 waypoints per route.
- Tracks: 8,000-point automatic track log; 10 stored tracks (up to 8,000 track points each). Allows you to follow your route in both directions (You can convert a track into a route).
- Chart symbols: 1,000
- Drawing lines: 2,000
- Place names: 1,000
- Colors for drawing: 8
- Alarms: XTE, anchor, arrival, speed, voltage, proximity waypoint, timer.

- Color palette: Normal, daylight (for use in sunlight), night (for dark environments), NOAA nautical chart colors.
- Tides: Built-in worldwide tidal data.
- Position format: LAT/LON
- Base map: K-Chart 3.0 – Scandinavia (Note: The map is for guidance only)
- External map: Compatible with K-Chart 2.0, K-Chart 3.0, C-MAP MAX, and Navionics+
- User data storage: Internal backup of user settings or external SD card.
- Plot intervals: 5 seconds to 60 minutes or 0.01 to 10 nautical miles.
- Plot scales: 0.001 to 700 nautical miles.
- Perspective view: ON/OFF (C-Map only)
- Celestial bodies: Sunrise/sunset, moon-rise/moonset GNSS receiver
- Receiver: 50-channel GNSS receiver that continuously tracks and uses up to 50 satellites to calculate and update your position.
- GNSS: Supports GPS, Beidou, and GLONASS.
- Startup time: Cold start: 29 seconds. Warm start: 1 second.
- Update rate: 1 second or 0.1 second.
- Accuracy: Position: 3 meters (95% without S/A). Speed: 0.1 meter/second without S/A.
- Dynamics: Altitude: 18,000 meters. Speed: 515 meters/second.
- Datum: WGS84.
- SBAS: Supported (all models).
- QZSS: Supported (all models).

GPS interface.

- GPS data: RS232/RS422 in/out, NMEA0183 V3.01 and V4.11.
- GPS input Baud Rate: Automatic scanning (4800, 9600, 19200, and 38400).
- GPS output baud rate: Selectable between 4800, 9600, 19200, and 38400

Supported NMEA Sentences

- Input: Automatic baud rate scanning + GGA, GLL, GSA, GSV, RMC, HDG, HDM, HDT, VTG, ZDA, MTW, VWR, VWT, MWD, VPW, VHW, TLL, TTM, VDO, VDM, GNS, MTA, RMA, DBT, DPT, MWV, BWC, XTE, ZDL, WPL, AAM, APB, BOD, RMB, DSC, MDA, RPM, XDR.
- Output: Baud rate selectable: 4800, 9600, 19200, 38400 + GGA, GLL, RMC, GSA, GSV, AAM, APA, APB, BOD, BWC, BWR, DBT, DPT, HDT, MTW, RMB, TLL, VTG, WPL, XTE, ZDA, ZTG, ZDL, MWD, VPW, VWR, VWT.
- Output to autopilot: APA, APB, XTE, BOD

Physical specifications

- Size:
 - TideON7" Series: 155.1 mm (H) x 241.3 mm (W) x 62.9 mm (D)
 - TideON 9" Series: 172.5 mm (H) x 295.5 mm (W) x 77.7 mm (D)
- Display:
 - TideON7" Series: 7-inch color TFT daylight-viewable LCD, 800 x 480 pixels
 - TideON 9" Series: 9-inch color TFT daylight-viewable LCD, 1024 x 600 pixels
- Waterproof rating:
 - Display Unit: IPX6

- GPS antenna: IPX6
- Temperature range:
 - Display Unit: -15°C to +55°C
 - and GPS antenna: -25°C to +70°C

Equipment List:

- Display Unit (including mounting bracket and thumb screws)
- Flush mount gasket for panel
- User and Installation Manual
- Front Cover and Extra Rain Cover
- Standard Accessory Package (one 8-pin power/data cable, 2 extra fuses, 4 bracket mounting screws, 8 panel mounting screws)

CONTENTS:

1. OPERATION OVERVIEW

- 1.1 Keyboard Guide
- 1.2 Power On and Off
- 1.3 Adjustment of Brightness and Day/Night Mode
- 1.4 Selection of Display Mode

2. PLOTTER DISPLAY OVERVIEW

- 2.1 Selection of Zoom Area
- 2.2 Moving the Cursor
- 2.3 Panning the Plotter Display
- 2.4 Centering the Own Ship Position
- 2.5 Chart
- 2.6 Perspective View
- 2.7 Course Line

- 2.8 Cursor
- 2.9 Ship Shape/Color
- 2.10 Range Circle
- 2.11 Drawing
- 2.12 Palet
- 2.13 Chart Orientation

3. TRACK

- 3.1 Change Color of Current Track
- 3.2 Change Plotting Interval for Current Track
- 3.3 Save Current Track
- 3.4 Delete Current Track
- 3.5 Delete Saved Track
- 3.6 Transfer saved track to route
- 3.7 Display saved track on plotter screen

4. WAYPOINT/MOB

- 4.1 Entering waypoints
- 4.2 Entering MOB Marker
- 4.3 Displaying waypoint name
- 4.4 Editing waypoints
- 4.5 Deleting waypoints
- 4.6 Editing waypoints on the plotter screen
- 4.7 Deleting waypoints on the plotter screen

5. ROUTES

- 5.1 Creating routes
- 5.2 Editing routes
- 5.3 Deleting routes

6. DESTINATION

- 6.1 Set destination with Cursor
- 6.2 Set destination with waypoint
- 6.3 Set route as destination
- 6.4 Set track as destination

- 6.5 Cancel destination
- 6.6 Distance measurement

7. ALARM

8. DRAWING FUNCTION

- 8.1 Chart symbols
- 8.2 Draw line
- 8.3 Draw place name
- 8.4 Delete/edit drawings

9. OTHER SETTINGS

10. N2K FUNCTION













11. DATA

12. INSTALLATION

1. OPERATION OVERVIEW



1.1 Keyboard Guide

	
	<ul style="list-style-type: none">• Plotter function: Move cursor up/down or change setting.
	<ul style="list-style-type: none">• Plotter function: Move cursor left.
	<ul style="list-style-type: none">• Plotter function: Move cursor right.
	<ul style="list-style-type: none">• Press once to display the menu for the current page, twice to open the MAIN MENU.
	<ul style="list-style-type: none">• Click to display the "Display menu". <i>Plotter function: Press once – plotter menu. Press twice – AIS menu. Press three times – MAIN MENU. Hold down to toggle track ON/OFF.</i>
	<ul style="list-style-type: none">• Cancel an optional action or activate graphic mode.
	<ul style="list-style-type: none">• Confirm input or data. <i>Plotter function: Long press – activate mark symbol. Short press – activate waypoint editing.</i>
	<ul style="list-style-type: none">• Plotter Zoom in: Enlarges the chart scale.
	<ul style="list-style-type: none">• Plotter Zoom out: Reduces the chart scale.
	<ul style="list-style-type: none">• Function button/menu: Displays the menu for other functions (GOTO, tide table, search, etc.)
	<ul style="list-style-type: none">• MOB Marker indicates the position of "man overboard". Long press – activates the "Man overboard" function.
	<ul style="list-style-type: none">• Long press – Turns the power on/off Short press – Adjusts the screen brightness and keyboard backlight

1.2 Power On and Off

- Power on: Press the power button, the device beeps and displays the "TideON" logo. Wait until the warning screen appears, then press to enter operational mode.
- Power off: Hold the power button until the screen turns off.

1.3 Adjustment of Brightness and Day/Night Mode

- Short press the brightness button to open the adjustment window.

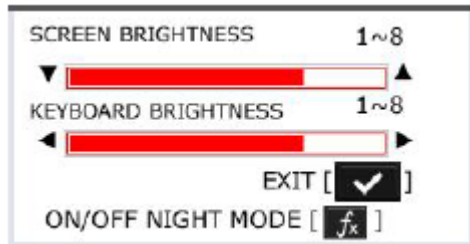



- Use the arrow keys to adjust the LCD brightness and keyboard backlight.
- Press to confirm and exit.
- When the window is open, you can switch between day and night mode.

Click  to toggle between day and night display.



1.4 Selection of Display Mode

- Press  or  in any display mode to open the icon window.
- Use the arrow keys to select the display mode and press to confirm.
- If some modes cannot be selected (grey icon), check the SETUP menu. (Not all functions are available on this model.)

2. PLOTTER DISPLAY OVERVIEW

2.1 Selection of Zoom Area

- Press + to zoom in and - to zoom out on the plotter display.

2.2 Moving the Cursor

- Use the arrow keys to move the Cursor. The Cursor position is shown in latitude/longitude at the top left, along with distance and bearing from own ship.

2.3 Panning the Plotter Display

- Use the Cursor to pan to the desired area. Place the Cursor at the edge of the screen to start panning.

2.4 Centering the Own Ship Position

- Press the centering button.  to center the own ship's position.

2.5 Chart

- Press menu on the plotter screen, select "Map", then press  to select .
- Select the layer "ON" or "OFF" and confirm.

2.6 Perspective View

- Only available on C-Map. Activated via the menu on the plotter screen.

2.7 Course Line

- Press "MENU".
- Select "Heading Line" in the menu and press. 
- Options: "Or", "Variable", "Max", "Timeline" or "HDG data".
- "COG Time Line": The length of the course line varies according to Speed to indicate the expected position after the selected time. 2

- Select "Cursor" in the menu. Options: "Standard" or "Full Screen". 2.9

Ship shape/color

- Select "Ship shape/color" in the menu and choose the desired setting.

2.10 Range Circle

- Select "Range Circle" in the menu. Choose "ON" and enter the radius, or select "OFF".

2.11 Drawing

- Select "Drawing" in the menu. Select "Mark", "Line", or "Place name". The user can adjust the size of marks and lines.

2.12 Palet

- Select "Palette" in the menu. Options: "Normal", "Daylight", "Night", or "NOAA".

2.13 Chart Orientation

- Select "Map Direction" in the menu. Options: "Normal", "North Up", "WPT Up", "COURSE Up", or "Head Up".
 - "Normal": The map does not move; only the boat's position changes.
 - "North Up": North is always at the top.
 - "WPT Up": Available only in GOTO mode, with the waypoint at the top.
 - "Course Up": Course over ground displayed at the top.
 - "Head Up": Boat's heading displayed at the top (requires an external heading signal).

3. TRACK

3.1 Change Color of Current Track

Hold the "MODE" button on the plotter screen to change the color of your current track (e.g., from red to green).

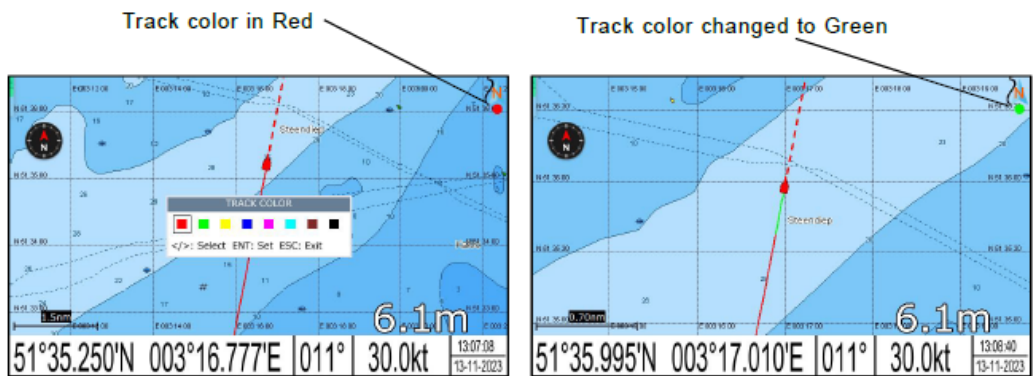

Press and hold **MODE** key until you see the track color box appear

3.2 Change Plotting Interval for Current Track

Select MAIN MENU → Track Log → Track Log Mode.

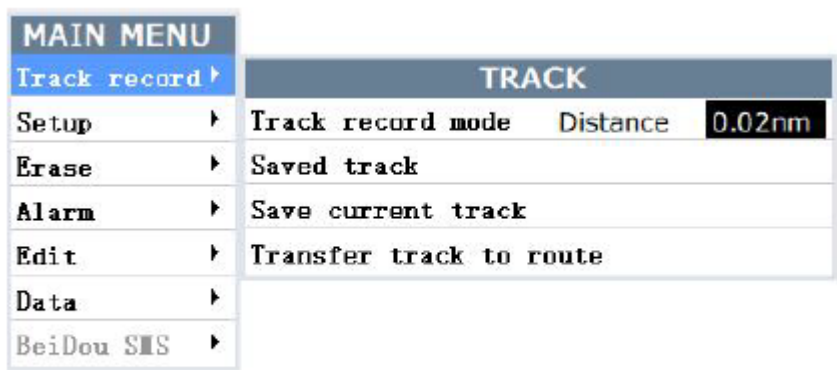

Choose MAIN MENU → Track record → Track record mode

- Time: Tracks are recorded and displayed at the selected time interval.
- Distance: Tracks are recorded and displayed at the selected distance interval.
- Auto: The interval changes automatically based on the zoom level.
- OFF: Tracks are not recorded.

3.3 Save Current Track

You can save the current track for later use. The color and name can be changed before saving.

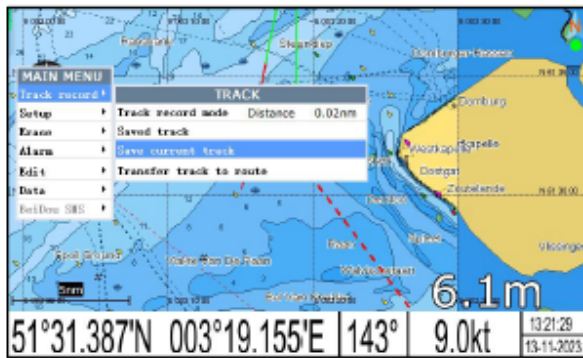

Choose MAIN MENU->Track record->Save current track

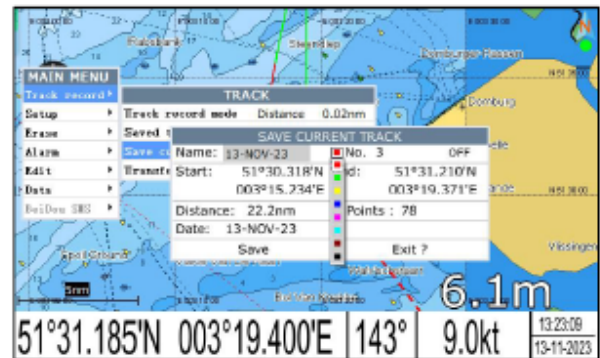

You can change the color and the name before save

3.4 Delete Current Track

Select MAIN MENU → Delete → Current Track.

3.4 Erase current track

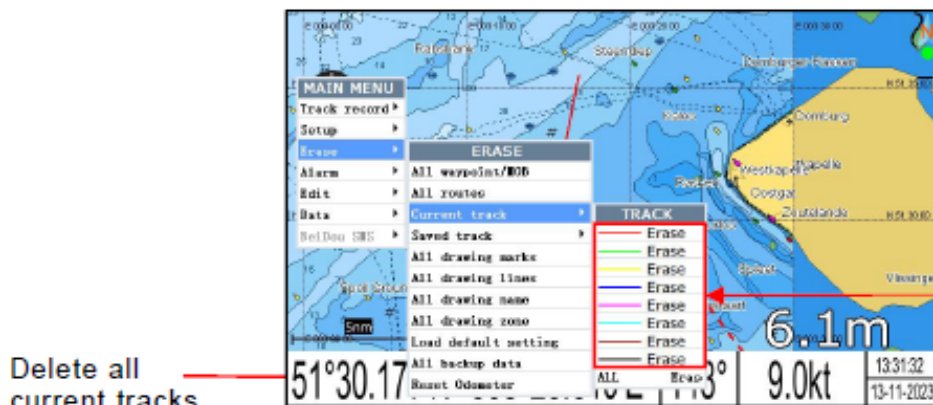

Delete all current tracks

Delete current track segment by color

Choose MAIN MENU → Erase → Current track

3.5 Delete Saved Track

Select MAIN MENU → Delete → Saved track.

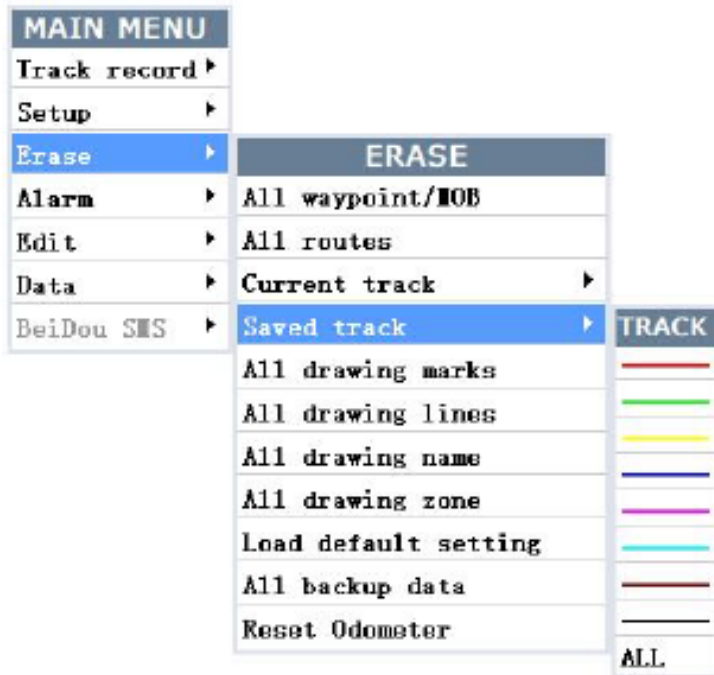

Choose MAIN MENU → Erase → Saved track

3.6 Transfer saved track to route

Select a saved track from the list, choose start and end points, name the route, and confirm.

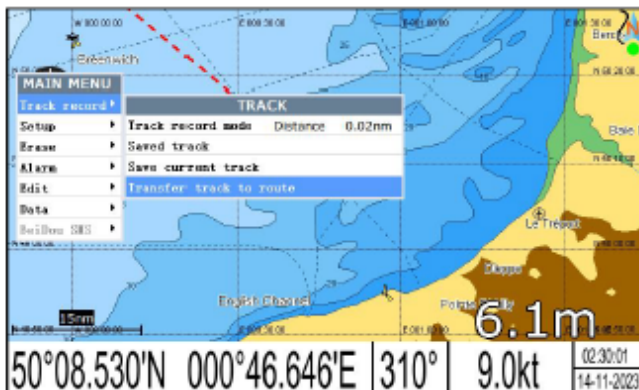

Choose MAIN MENU → Track record → Transfer track to route



Choose a saved track from the list

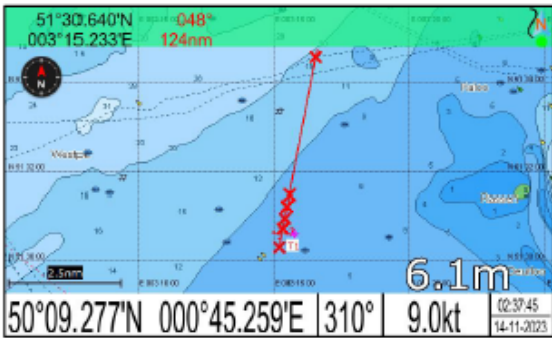

Move the cursor to the starting point and press

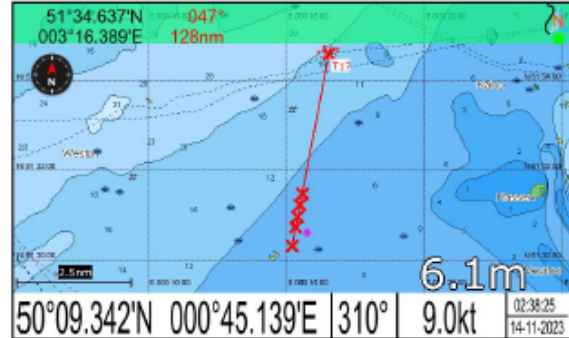

Move the cursor to the ending point and press again

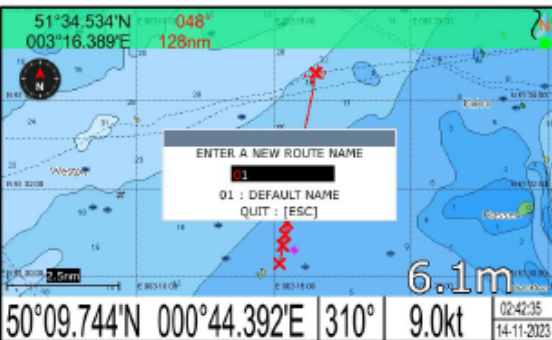

Enter the name of the new route and press to confirm



A new route is created

3.7 Display saved track on plotter screen

Select "Track" in the plotter menu, choose the color and set it to "ON" or "OFF".

4. WAYPOINT/MOB

4.1 Entering waypoints

- With Cursor: Place the Cursor, press to edit if necessary. name/position/symbol/color.

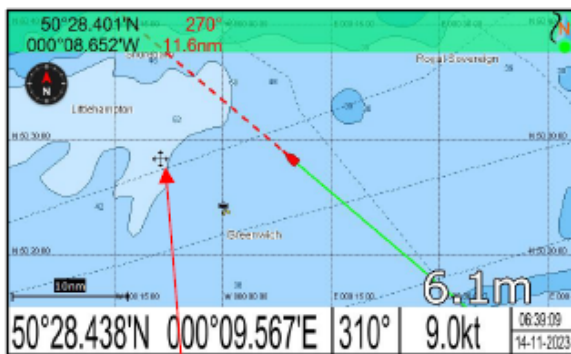

Move the cursor to the location desired for a waypoint

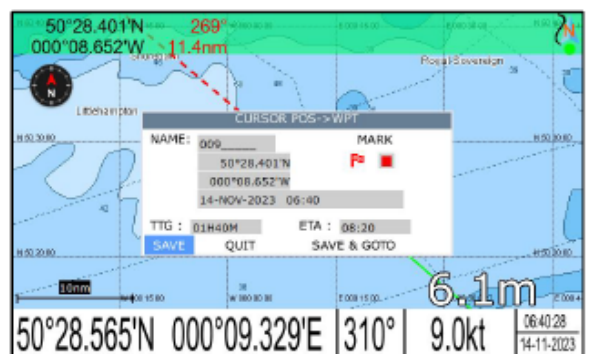

Press , choose "SAVE" and press again

- At own ship's position: Press briefly when the Cursor is not visible. (You remove the Cursor by clicking .)

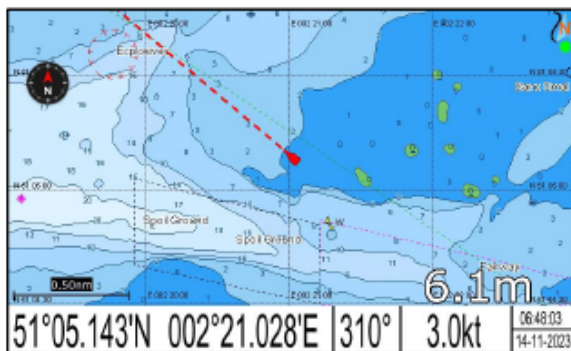

Make sure no cursor is seen on the plotter screen



Press , choose "SAVE" and press again

- From the waypoint list: Go to MAIN MENU (click "MENU" twice) → Edit → Waypoint → NEW → "SAVE."

4.2 Entering MOB Marker

Only one MOB Marker can be active at a time. Hold the button down to activate. Select "YES" to set MOB as the destination, or "NO" to save as a waypoint.

4.3 Displaying waypoint name

See section 2, PLOTTER CONFIG → Waypoint.

4.4 Editing waypoints

Go to MAIN MENU → Edit → Waypoint, select the waypoint, edit the name, position, symbol, color, and save.

4.5 Deleting waypoints

Go to MAIN MENU → Edit → Waypoint, select the waypoint, choose "ERASE" and confirm.

To delete all: MAIN MENU → Delete → All waypoints/MOB.

4.6 Editing waypoints on the plotter screen

Move the Cursor close to the waypoint and press to edit.

4.7 Deleting waypoints on the plotter screen

Move the Cursor close to the waypoint and press to delete.

5. ROUTES

5.1 Creating routes

Go to MAIN MENU → Edit → Route → NEW, name the route, and select waypoints.

5.2 Editing routes

Select the route, select the waypoint, and choose "Change" to replace the waypoint.

5.3 Deleting routes

Select the route, choose "ERASE" and confirm.

To delete all: MAIN MENU → Delete → All routes.

6. DESTINATION

6.1 Set destination with Cursor

Open the FUNCTIONS menu, (click ) select "Goto cursor", place the cursor and confirm.

6.2 Set destination with waypoint

Open the FUNCTIONS menu, select "Goto WPT", choose the waypoint.

6.3 Set route as destination

Open the FUNCTIONS menu, select "Goto route", choose the route, and select "Forward" or "Reverse".

6.4 Set track as destination

Open the FUNCTIONS menu, select "Goto track", choose the track, and select "Forward" or "Reverse".

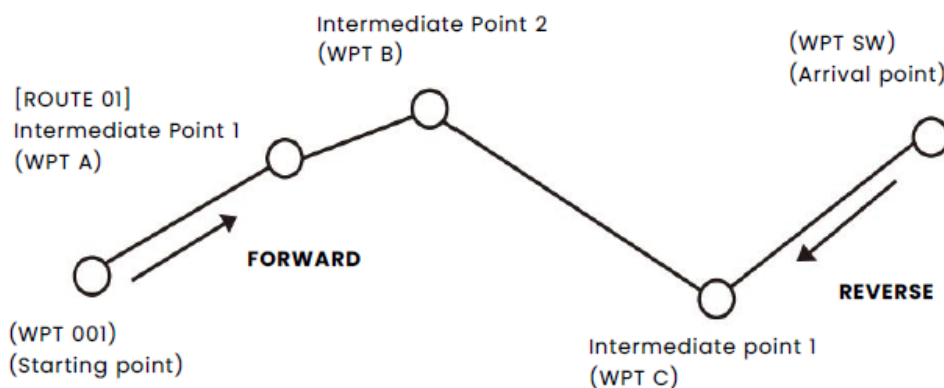

Meaning of forward and reverse

6.5 Cancel destination

Open the FUNCTIONS menu, select "Stop goto".

6.6 Distance measurement

Open the FUNCTIONS menu, select "Distance", measure multiple points, and optionally save as a route.

7. ALARM

Types of alarms:

- Anchor, Arrival, XTE (cross-track error), speed, voltage, timer.

Alarm settings:

Go to MAIN MENU → Alarm, select alarm type, set the value, and choose "ON."

Deactivate alarm:

Press any key to silence the buzzer. The alarm icon will disappear only after the cause has been resolved.

8. DRAWING FUNCTION

8.1 Chart symbols

Select FUNCTION menu → Drawing → Marker. Place the Cursor, select symbol and color, then save.

8.2 Draw line

Select FUNCTION menu → Drawing → Line. Draw a line between points, then save.

8.3 Draw place name

Select FUNCTION menu → Drawing → Place name. Enter the name, then save.

8.4 Delete/edit drawings

Move the Cursor close to the marker/line/place name, then press to edit or delete.

9. OTHER SETTINGS

- Chart scale: Select between "Nm" or "Ratio."

- Units: Select between nautical miles/knot, kilometers/km/h, or miles/mph.
- **Depth unit:** Feet, fathoms, or meters.
- **Bearing reference:** True or magnetic.
- **Magnetic variation:** Automatic or manual.
- Deviation: Enter to correct GPS or chart errors.
- Time: Set the time offset to UTC, choose 12- or 24-hour format.
- **TTG/ETA speed:** Automatic (GPS) or manual.
- Key sound: On/off .
- **Windshield: On /off .**
- **GPS settings:** Select output data, datum, smoothing, and GNSS mode.
- **NMEA data display:** Used for installation testing.

10. N2K FUNCTION

10.1 Function Overview

The N2K functionality enables the device to connect to the N2K network and share data bidirectionally. The device can operate as an N2K sender (sharing data with the network) or as an N2K receiver (receiving data from other devices).

10.2 Connection to the N2K Network

A basic N2K network requires at least one data-sharing device and one data-receiving device. Minimum requirements:

- 2 termination resistors
- 2 extension cables
- 3 T-connectors
- 1 power cable

10.3 Data Sharing

Settings for N2K data sharing and receiving are configured via the satellite screen.

10.3.1 Data Sharing Settings

There are six data types: GPS, course, depth, wind, environment, and AIS. You can individually select whether each type should be shared.

10.3.2 Data Reception Settings

You can receive five types of N2K data: GPS, course, depth, wind, and AIS. For AIS, you can only choose whether to receive data from N2K sources (all AIS data on the network).

For the other four (GPS, course, depth, wind), you can prioritize the data source and select a specific device as the source.

Setting: SATELLITE MENU → Preferred Data Source → GPS (or course/depth /wind) → N2K.

A list of N2K devices will be displayed. Use the arrow keys to select a device and press to return.

10.3.3 Overview of received N2K data on the network On any screen, press (3 times for chart screen, 2 times for others) to open the 'MAIN MENU'. Select 'Setup', then 'NMEA2000 Network Analyse'. Here you can view all N2K data received by the device.

11. DATA

11.1 Connecting output data to external equipment

11.1.1 Output of navigation data

The following NMEA0183 sentences can be sent to external equipment: GGA, GLL, RMC, GSA, GSV, AAM, APA, APB, BOD, BWC, BWR, DBT, DPT, HDT, MTW, RMB, TLL, VTG, WPL, XTE, ZDA, ZTG, ZDL, MWD, VPW, VWR, VWT.

Baud Rate can be selected: 4800, 9600, 19200, 38400.

11.1.1.1 Connection of wires to external equipment

Connect pin 5+ (green) and pin 6- (brown) to the input of the external equipment.

11.1.1.2 Selection of output sentences

Activate output in the Satellite menu and select the desired NMEA0183 sentences.

11.1.1.3 Selection of output baud rate

Select between 4800, 9600, 19200, and 38400.

11.2 Connection of NMEA0183 sentences from external equipment The following sentences can be received: GGA, GLL, GSA, GSV, RMC, HDG, HDM, HDT, VTG, ZDA, MTW, VWR, VWT, MWD, VPW, VHW, TLL, TTM, VDO, VDM, GNS, MTA, RMA, DBT, DPT, MWV, BWC, XTE, ZDL, WPL, AAM, APB, BOD, RMB, DSC, MDA, RPM, XDR.

Baud Rate: automatic scanning (4800, 9600, 19200, 38400).

11.2.2 Connecting wires from external equipment

Connect pin1+ (yellow) and pin2- (white) to the output of the external equipment.

POWER/DATA

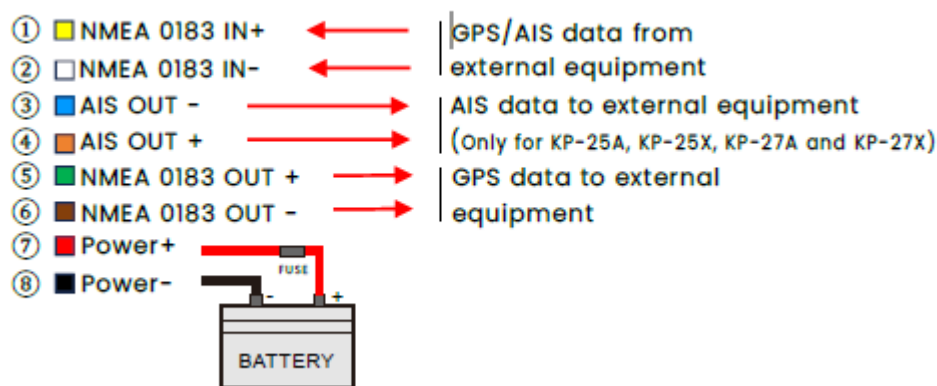

11.4 Import and export of user data

All user data (waypoints, routes, tracks, marks, lines, and place names) can be imported/exported via SD card.

11.4.1.1 Importing data in basic mode

Insert the SD card with ODF data, then go to MAIN MENU → Data → Data In.

11.4.1.2 Exporting data in basic mode

Insert the SD card, then go to MAIN MENU → Data → Data Out.

11.4.2 Advanced Mode

Select data types and date range for export/import.

11.5 Recording and Playback

You can record all navigation data (position, Speed, course, AIS, depth) on the SD card and play it back later.

12. INSTALLATION

12.1 Contents Check

When you open the box for the first time, ensure the following items are included:

- Display Unit (including mounting bracket and thumb screws)
- GPS Patch Antenna
- Flushmount Gasket
- User and Installation Manual
- Front Cover and Extra Rain Cover
- Standard Accessory Kit: 8-pin power/data cable, 2 fuses, 4 bracket mounting screws, 8 panel mounting screws

12.2 Installation of the Unit

Three Methods: Desktop Mounting, Hanging, Built-in Panel Mounting.

12.2.1 Desktop Mounting

The mounting bracket must be secured with 5 mm screws.

Avoid locations with vibrations, water splashes, or direct sunlight.

Maintain at least 10 cm clearance between the back of the unit and the wall.

Secure the unit firmly with the thumbscrews.

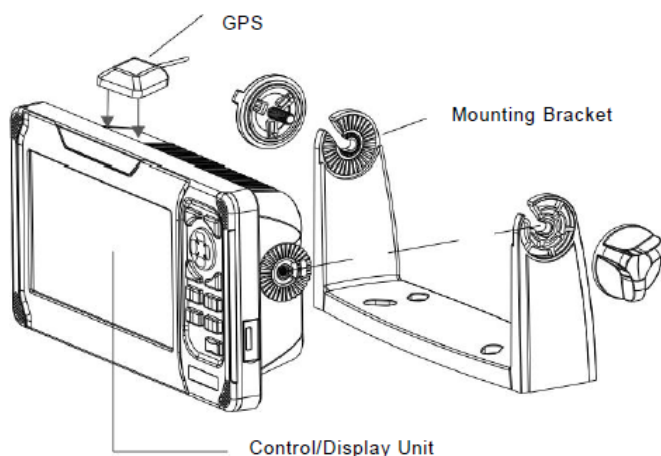

12.2.2 Hanging

Attach the bracket using the supplied screws.

Secure the plotter with the supplied thumbscrews.

Ensure the hanging location can support the weight and is secure.

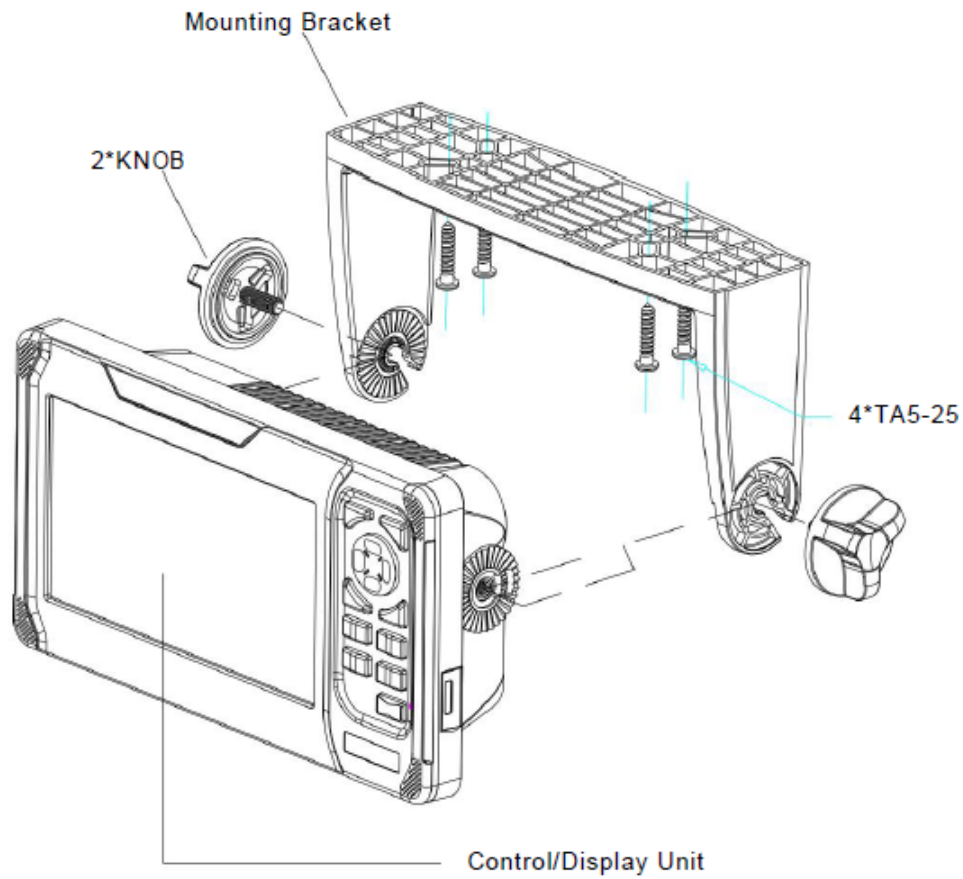

12.2.3 Built-in panel mounting

Cut a hole in the panel according to the template.

Remove the top panel strips from the front.

Insert the unit into the hole, fasten with screws, and reattach the panels.

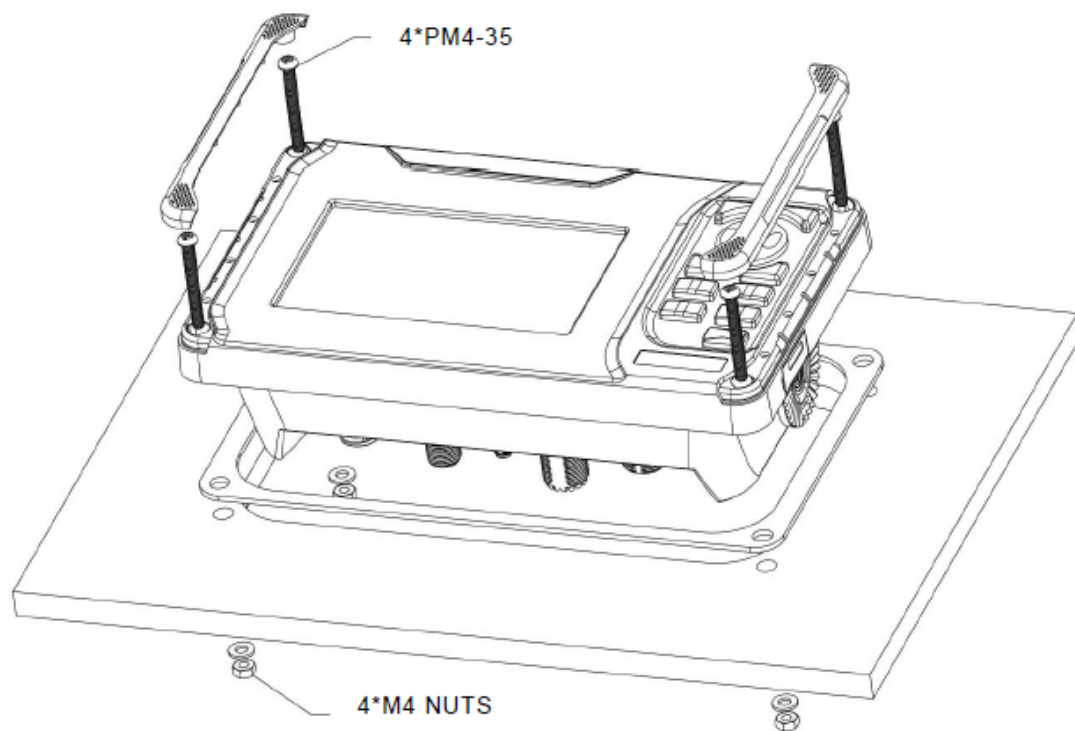

Manufacturer and Distributor:

Palby Marine A/S

Korsvej 3

6000 Kolding – Denmark

CVR no: 13619883

palby@palby.dk